

**Zavod za gradbeništvo  
Slovenije**  
**Slovenian National Building and  
Civil Engineering Institute**  
**Dimičeva 12,**  
**1000 Ljubljana, Slovenija**  
Tel.: +386 (0)1-280 44 72  
Fax: +386 (0)1-436 74 49  
e-mail: [info.ta@zag.si](mailto:info.ta@zag.si)  
<http://www.zag.si>

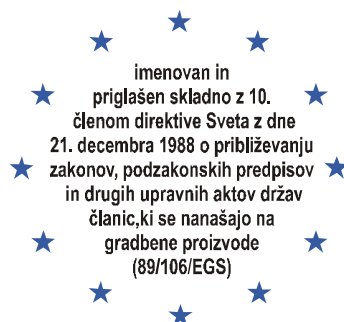

član EOTA  
Member of EOTA

## European Technical Approval

## ETA-10/0423

[English translation prepared by ZAG – Original version in Slovenian language]

Komercialno ime  
*Trade name*

**ATS evo**

Imetnik soglasja  
*Holder of approval*

**FRIULSIDER S.p.A.**  
**via Trieste 1**  
**33048 San Giovanni al Natisone (UD)**  
**Italy**

Tip gradbenega proizvoda in  
njegova predvidena uporaba

**Torzijsko kontrolirano zatezno kovinsko sidro iz  
galvansko pocinkanega jekla velikosti M6, M8,  
M10, M12 in M16 za vgradnjo v razpokani in  
nerazpokani beton**

*Generic type and use  
of construction product*

*Torque controlled expansion anchor made of galvanised steel  
of sizes M6, M8, M10, M12 and M16 for use in cracked and  
non-cracked concrete*

Veljavnost od  
*Validity from*  
do  
*to*

**12.03.2012**

**13.12.2015**

Proizvodni obrat  
*Manufacturing plant*

**FRIULSIDER S.p.A.**  
**via Trieste 1**  
**33048 San Giovanni al Natisone (UD)**  
**Italy**

To soglasje zamenjuje:  
*This Approval replaces:*

ETA-12/0423 veljavno od 13.12.2010 do  
13.12.2015  
*ETA-12/0423 valids from 13.12.2010 to 13.12.2015*

To Evropsko tehnično soglasje  
vsebuje  
*This European Technical Approval contains*

16 strani vključno s 8 prilogami, ki so sestavni del  
tega soglasja  
*16 pages including 8 annexes, which form an integral part of  
the document*



Evropska organizacija za tehnična soglasja  
European Organisation for Technical Approvals

## I LEGAL BASES AND GENERAL CONDITIONS

1. This European Technical Approval is issued by the Slovenian National Building and Civil Engineering Institute (ZAG) in accordance with:
  - Council Directive 89/106/EEC of 21 December 1988 on the approximation of laws, regulations and administrative provisions of Member States relating to construction products<sup>1</sup>, modified by the Council Directive 93/68/EEC<sup>2</sup> and Regulation (EC) N°1882/2003 of the European Parliament and of the Council<sup>3</sup>,
  - Zakon o gradbenih proizvodih (ZGPro)<sup>4</sup>,
  - Common Procedural Rules for Requesting, Preparing and the Granting of European Technical Approvals set out in the Annex of Commission Decision 94/23/EC<sup>5</sup>,
  - Guideline for European Technical Approval of “Metal Anchors for use in Concrete“, Part 1 “Anchors in General” and Part 2: Torque controlled expansion anchors”, ETAG 001, edition October 1997, amended November 2006.
2. The Slovenian National Building and Civil Engineering Institute (ZAG) is authorised to check whether the provisions of this European Technical Approval are met. Checking may take place in the manufacturing plant. Nevertheless, the responsibility for the conformity of the products with the European Technical Approval and for their fitness for the intended use remains with the holder of the European Technical Approval.
3. This European Technical Approval is not to be transferred to manufacturers or agents of manufacturer other than those indicated on page 1; or manufacturing plants other than those indicated on page 1 of this European Technical Approval.
4. This European Technical Approval may be withdrawn by the Slovenian National Building and Civil Engineering Institute (ZAG), in particular pursuant to information by the Commission according to Article 5 (1) of the Council Directive 89/106/EEC.
5. Reproduction of this European Technical Approval including transmission by electronic means shall be in full. However, partial reproduction can be made with the written consent of the Slovenian National Building and Civil Engineering Institute (ZAG). In this case partial reproduction has to be designated as such. Texts and drawings of advertising brochures shall not contradict or misuse the European Technical Approval.
6. The European Technical Approval is issued by the approval body in its official language. This version corresponds fully to the version circulated within EOTA. Translations into other languages have to be designated as such.

---

<sup>1</sup> Official Journal of the European Communities N° L 40, 11.2.1989, p.12

<sup>2</sup> Official Journal of the European Communities N° L 220, 30.8.1993, p.1

<sup>3</sup> Official Journal of the European Union N° L 284, 31.10.2003, p.1

<sup>4</sup> Official Gazette of the Republic of Slovenia, N° 52/00 and N° 110/02

<sup>5</sup> Official Journal of the European Communities N° L 17, 20.1.1994, p.34

## **II SPECIFIC CONDITIONS OF THE EUROPEAN TECHNICAL APPROVAL**

### **1 Definition of product and intended use**

#### **1.1 Definition of product**

The ATS evo in the range of M6, M8, M10, M12 and M16 is an anchor made of galvanised steel, which is placed into a drilled hole and anchored by torque-controlled expansion.

For the installed anchor see Figure given in Annex 1 and 4.

#### **1.2 Intended use**

The anchor is intended to be used for anchorages for which requirements for mechanical resistance and stability and safety in use in the sense of the Essential Requirements 1 and 4 of Council Directive 89/106/EEC shall be full filled and failure of anchorages made with these products would compromise the stability of the works, cause risk to human life and/or lead to considerable economic consequences. The anchor is to be used only for anchorages subjected to static and quasi-static loading in reinforced or non reinforced normal weight concrete of strength classes from C20/25 to C50/60 according to EN 206-1:2003. It may be anchored in cracked and non-cracked concrete.

The anchor may only be used in concrete subject to dry internal conditions.

The anchor may be used for anchorages with requirements related to resistance to fire.

The provisions made in this European Technical Approval are based on an assumed working life of the anchor of 50 years. The indications given on the working life cannot be interpreted as a guarantee given by the manufacturer, but are to be regarded only as a means for choosing the right products in relation to the expected economically reasonable working life of the works.

### **2 Characteristics of product and methods of verification**

#### **2.1 Characteristics of product**

The anchor corresponds to the drawings and provisions given in Annexes 1 to 4. The characteristic material values, dimensions and tolerances of the anchor not indicated in these Annexes 3 and 4 shall correspond to the respective values laid down in the technical documentation<sup>6</sup> of this European Technical Approval. The characteristic anchor values for the design of anchorage are given in Annexes 5 and 6. The characteristic anchor values for the design of anchorages regarding resistance to fire are given in Annexes 7 and 8. They are valid for use in a system that is required to provide a specific fire resistance class.

Each anchor is marked with the product name, nominal drill hole diameter and maximum thickness of the fixture.

As an example: FM-ATS  $\phi$  15/20

---

<sup>6</sup> The technical documentation of this European Technical Approval is deposited at the Slovenian National Building and Civil Engineering Institute (ZAG) and, as far as relevant for the tasks of the approved bodies involved in the attestation of conformity procedure, is handed over the approved bodies.

The anchor shall only be packaged and supplied as a complete unit.

## **2.2 Methods of verification**

The assessment of fitness of the anchor for the intended use in relation to the requirements for mechanical resistance, stability and safety in use in the sense of the Essential Requirement 1 and 4 has been made in accordance with the "Guideline for European Technical Approval of Metal Anchors for use in Concrete", Part 1 "Anchors in general" and Part 2 "Torque-controlled expansion anchors", on the basis of Option 1.

The assessment of the anchor for the intended use in relation to the requirements for resistance to fire has been made in accordance with the Technical Report TR 020 "Evaluation of anchorages in concrete concerning resistance to fire".

## **3 Evaluation and attestation of conformity and CE marking**

### **3.1 System of attestation of conformity**

According to the decision 96/582/EC the European Commission<sup>7</sup> the system 1 of attestation of conformity applies.

This system of attestation of conformity is defined as follows:

System 1: Certification of the conformity of the product by an approved certification body on the basis of:

a) tasks for the manufacturer:

- (1) factory production control;
- (2) further testing of samples taken at the factory by the manufacturer in accordance with a control plan.

b) tasks for the approved body:

- (3) initial type-testing of the product;
- (4) initial inspection of factory and of factory production control;
- (5) continuous surveillance, assessment and approval of factory production control.

### **3.2 Responsibilities**

#### **3.2.1 Tasks of the manufacturer**

##### **3.2.1.1 Factory production control**

The manufacturer shall exercise permanent internal control of production of concerned product. All the elements, requirements and provisions adopted by the manufacturer are documented in a systematic manner in the form of written policies and procedures, including records of results performed. This production control system ensures that the product is in conformity with the European technical approval.

The manufacturer may only use raw materials stated in the technical documentation of this European technical approval. The incoming raw materials shall be subject to controls and tests by the manufacturer before acceptance. Check of incoming materials shall include control of the inspection documents presented by the manufacturer of the raw

---

<sup>7</sup> Official Journal of the European Communities L 198/31 of 25.7.1997

materials (comparison with nominal values) by verifying dimensions and determining the material properties, e.g. tensile strength, hardness, surface finish

The manufactured components of the anchor shall be subjected to the following tests:

- Dimensions of the component parts:
  - screw (thread, lengths, wrench, marking);
  - sleeve (length, thickness, catch size);
  - cone (thread, diameters);
  - hexagonal nut (thread, wrench, height);
  - washer (diameter, thickness).
- Material properties:
  - screw (yielding and ultimate tensile strength);
  - sleeve (hardness);
  - cone (hardness);
  - hexagonal nut (proof load or hardness);
  - washer (hardness).
- Visual control of correct assembly and of completeness of the anchor.

The factory production control shall be in accordance with the “Control Plan” of 13.12.2010 relating to the European technical approval ETA–10/0423 issued on 13.12.2010, which is part of the technical documentation of this European technical approval. The “Control Plan” is laid down in the context of the factory production control system operated by the manufacturer and deposited at the Slovenian National Building and Civil Engineering Institute (ZAG).

The results of factory production control shall be recorded and evaluated in accordance with the provisions of the “Control Plan”.

#### 3.2.1.2 Other tasks of the manufacturer

The manufacturer shall, on the basis of a contract, involve a body which is approved for the tasks referred to in a section 3.1 in the field of torque-controlled expansion anchors in order to undertake the actions laid down in section 3.3. For this purpose the “Control Plan” referred to in sections 3.2.1.1 and 3.2.2 shall be handed over by the manufacturer to the approved body or bodies involved.

The manufacturer shall make a declaration of conformity, stating that the construction product is in conformity with the provisions of the European technical approval ETA–10/0423 issued on 13.12.2010.

#### 3.2.2 Tasks of notified bodies

The notified body shall perform the:

- initial type testing of the product,
- initial inspection of factory and of factory production control,
- continuous surveillance, assessment and approval of factory production control.

in accordance with the provisions laid down in the “Control plan” of 13.12.2010, which is the part of technical documentation of this European technical approval.

The notified body shall retain the essential points of its actions referred to above and state the results obtained and conclusions drawn in a written report.

The notified certification body involved by the manufacturer shall issue an EC certificate of conformity control stating the conformity with the provisions of this European technical approval.

In cases where the provisions of the European technical approval and its "Control Plan" are no longer fully filled the certification body shall withdraw the certificate of conformity and inform the Slovenian National Building and Civil Engineering Institute (ZAG) without delay.

### **3.3 CE-Marking**

The CE marking shall be affixed on each packaging of anchors. The symbol "CE" shall be followed by the identification number of the certification body, and be accompanied by the following additional information:

- identification number of the certification body;
- name and identifying mark of the producer and manufacturing plant;
- the last two digits of the year in which CE – marking was affixed;
- number of the EC certificate of conformity;
- number of the European Technical Approval;
- use category ETAG 001 – 2 (Option 1);
- size of the anchor.

## **4 Assumptions under which the fitness of the product for the intended use was favourably assessed**

### **4.1 Manufacturing**

The European technical approval is issued for the product on the basis of agreed data/information, deposited with the Slovenian National Building and Civil Engineering Institute (ZAG), which identifies the product that has been assessed and judged. Changes to the product or production process, which could result in this deposited data/information being incorrect, should be notified to the Slovenian National Building and Civil Engineering Institute (ZAG) before the changes are introduced. The Slovenian National Building and Civil Engineering Institute (ZAG) will decide whether or not such changes affect the ETA and consequently the validity of the CE marking on the basis of the ETA and if so whether further assessment or alternations to the ETA, shall be necessary.

### **4.2 Installation**

#### **4.2.1 Design of anchorages**

The fitness of the anchors for the intended use is given under the following conditions:

The anchorages are designed in accordance with the "Guideline for European Technical Approval of Metal Anchors for use in Concrete", Annex C, Method A for torque controlled expansion anchors under the responsibility of an engineer experienced in anchorages and concrete work.

Verifiable calculation notes and drawings are prepared taking account of the loads to be anchored.

The position of the anchor is indicated on the design drawings (e.g. position of the anchor relative to reinforcement or to support, etc.).

The design of anchorages under fire exposure has to consider the conditions given in the Technical Report TR 020 "Evaluation of anchorages in concrete concerning resistance to fire". The relevant characteristic anchor values are given in Annex 7 Table 9 for resistance to fire under tension loads and in Annex 8 Table 10 for resistance to fire under shear loads. The design methods covers anchors with a fire attack from one side only. If

the fire attack is from more than one side, the design method may be taken only if edge distance of the anchor is  $c \geq 300$  mm.

#### 4.2.2 Installation of anchors

The fitness for use of the anchor can only be assumed if the following conditions are met:

- Anchor installation carried out by appropriately qualified personnel and under the supervision of the person responsible for technical matters on the site.
- Use of the anchor only as supplied by the manufacturer without exchanging the components of an anchor.
- Anchor installation in accordance with the manufacturer's specifications and drawings using the appropriate tools.
- Thickness of the fixture corresponding to the range of required thickness values for the type of anchor.
- Checks before placing the anchor to ensure that the strength class of the concrete in which the anchor is to be placed is in the range given and is not lower than that of the concrete to which the characteristic loads apply for.
- Check of concrete being well compacted, e.g. without significant voids.
- Cleaning of the hole of drilling dust.
- Anchor installation ensuring the specified embedment depth.
- Keeping of the edge distance and spacing to the specified values without minus tolerances.
- Positioning of the drill holes without damaging the reinforcement.
- In case of aborted hole: new drilling at a minimum distance away of twice the depth of the aborted hole or smaller distance if the aborted drill hole is filled with high strength mortar and if under shear or oblique tension load it is not to the anchor in the direction of load application.
- Application of the torque moment given in Annex 4 using a calibrated torque wrench.

#### 4.2.3 Responsibility for the manufacturer

It is in the responsibility of the manufacturer to ensure that the information on the specific conditions according to 1 and 2 including Annexes referred to 4.2.1, 4.2.2 is given to those who are concerned. This information may be made by reproduction of the respective parts of the European Technical Approval. In addition, all installation data shall be shown clearly on the packaging and/or on an enclosed instruction sheet, preferably using illustration.

The minimum data required are:

- drill bit diameter;
- thread diameter;
- maximum thickness of the fixture;
- minimum installation depth;
- torque moment;
- information on the installation procedure, including cleaning of the hole, preferably by means of an illustration;
- reference to any special installation equipment needed;
- identification of the manufacturing batch.

All data shall be presented in a clear and explicit form.

Leading expert:

Duška Drobnič, M.Sc., (Civ.Eng.)

Service for Technical Approvals:

Franc Capuder, M.Sc., (Civ.Eng.)



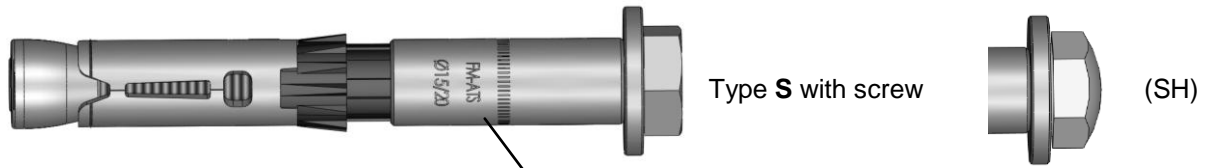

Type S with screw

(SH)

**Marking:** Identification mark of the producer - trade name of the anchor  
nominal drill hole diameter / max thickness of fixture  
(and line for minimum embedment and max thickness of fixture)  
e.g.: FM-ATS  
Ø15/20

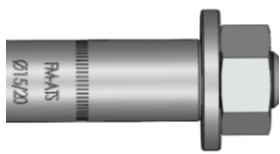

Type B with threaded bar



Type SK with  
countershunk screw

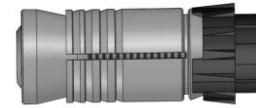

Sleeve for M16 size

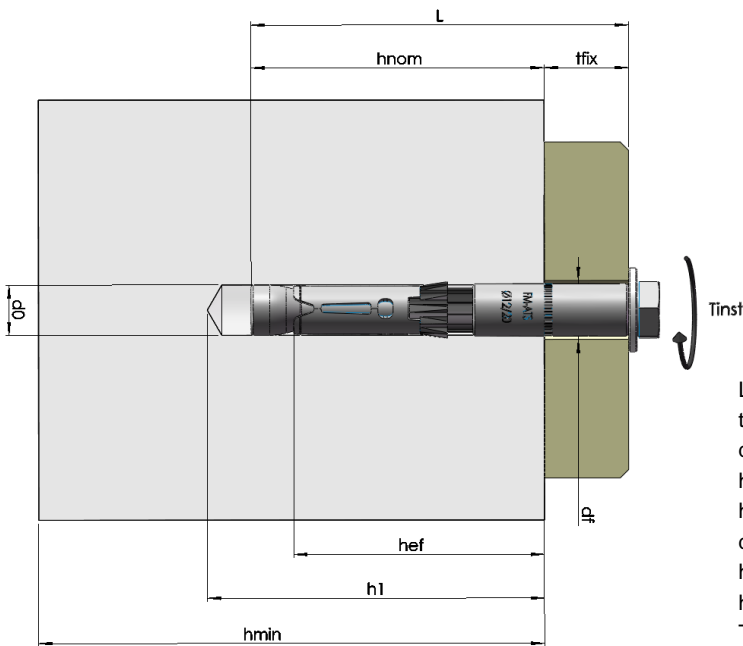

- L = length of the anchor (mm)
- t<sub>fix</sub> = thickness of fixture (mm)
- d<sub>0</sub> = nominal drill hole diameter (mm)
- h<sub>nom</sub> = minimum installation depth (mm)
- h<sub>ef</sub> = effective anchorage depth (mm)
- d<sub>f</sub> = diameter of clearance hole in the fixture (mm)
- h<sub>1</sub> = depth of drill hole (mm)
- h<sub>min</sub> = minimum thickness of the concrete member (mm)
- T<sub>inst</sub> = torque moment (Nm)

**ATS evo**

Product and intended use

**Annex 1**

of the European Technical  
Approval

**ETA-10/0423**

ATS evo-S

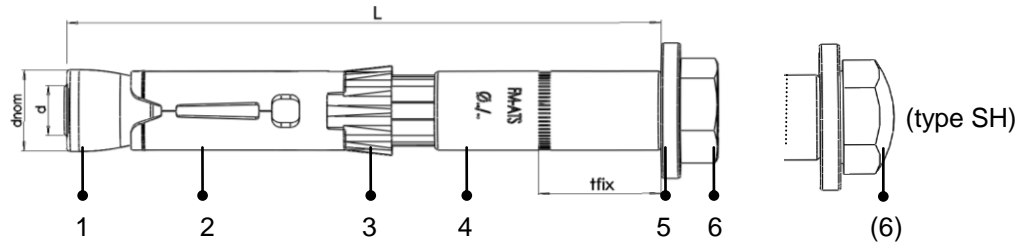

ATS evo-B

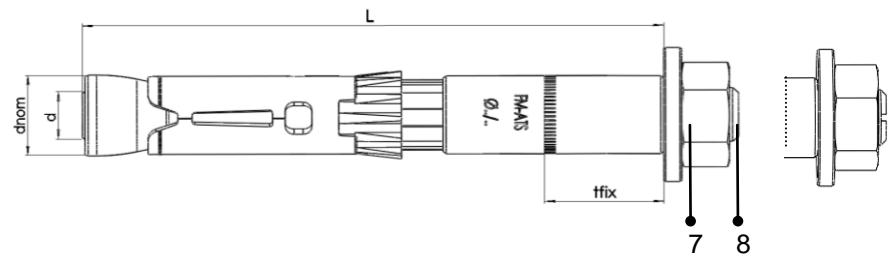

ATS evo-SK

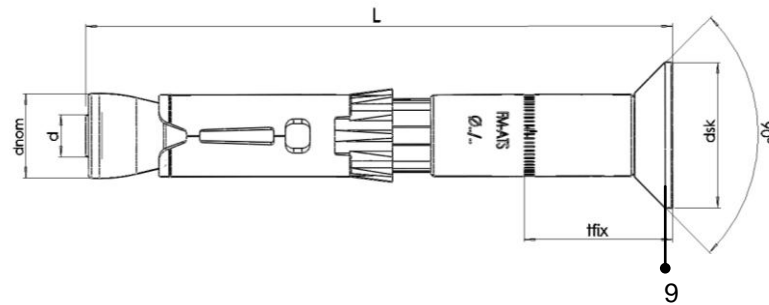

- 1 Cone
- 2 Expansion sleeve
- 3 Plastic sleeve
- 4 Distance sleeve
- 5 Washer
- 6 Hexagonal screw
- 7 Hexagonal nut
- 8 Threaded bar
- 9 Countersunk screw

**ATS evo**

Product and components

**Annex 2**

of the European Technical Approval

**ETA-10/0423**

**Table 1: Dimensions**

Anchor size		M6	M8	M10	M12	M16	
Nominal diameter of anchor	$d_{nom}$ [mm]	10	12	15	18	24	
Minimum installation depth	$h_{nom} \geq$ [mm]	60	70	80	100	115	
Length of the anchor	L [mm]	$t_{fix} + 60$	$t_{fix} + 70$	$t_{fix} + 80$	$t_{fix} + 100$	$t_{fix} + 115$	
Thickness of the fixture	Type S (SH) /B	$t_{fix,min}$ [mm]	0	0	0	0	
	Type SK	$t_{fix,min}$ [mm]	5	6	7	8	
	Type S (SH)/B/SK	$t_{fix,max}$ [mm]	200	250	300	350	
Nominal diameter of the head of the countersunk screw		$d_{sk}$ [mm]	17	21	26	31	-

**Table 2: Materials**

Part of anchor		Material
1	Cone	hardened steel EN 10087 <sup>1) - 2)</sup>
2	Expansion sleeve	M6+M12 hardened steel EN 10132 <sup>1)</sup> - M16 steel EN 10087 <sup>1)</sup>
3	Plastic sleeve	Pa6 ISO 1874/1
4	Distance sleeve	Steel EN 10025 <sup>1)</sup>
5	Washer	Steel EN 10139 <sup>1)</sup>
6	Hexagon screw	Steel grade 8.8 EN ISO 898/1 <sup>1)</sup> (DIN 931 -DIN 933 - type SH=head large)
7	Hexagonal nut	Steel grade 8 EN ISO 898/2 <sup>1)</sup> (DIN 934)
8	Threaded bar	Steel grade 8.8 EN ISO 898/1 <sup>1)</sup>
9	Countersunk screw	Steel grade 8.8 EN ISO 898/1 <sup>1)</sup>

<sup>1)</sup> zincplated 5 $\mu$ m according to EN ISO 4042<sup>2)</sup> functional coating**ATS evo**

Dimensions of anchors and materials

**Annex 3**

of the European Technical Approval

**ETA-10/0423**

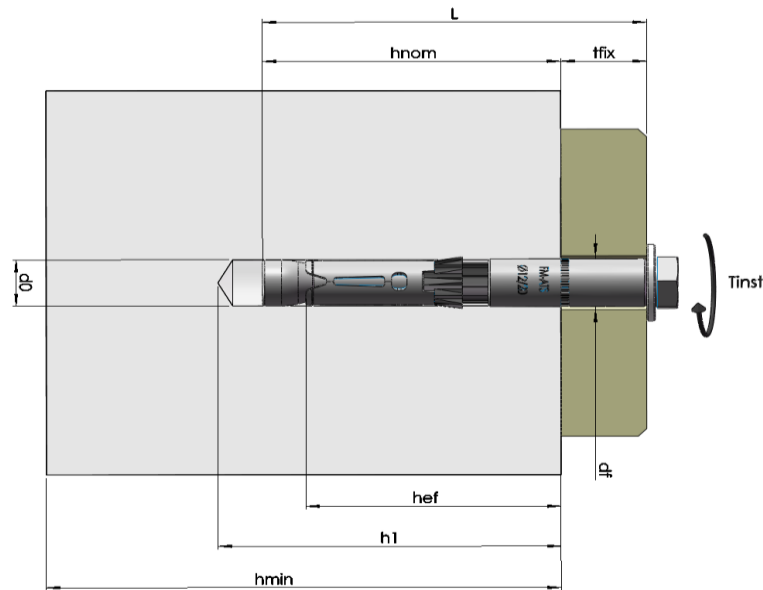

**Table 3: Installation data**

Anchor size		<b>M6</b>	<b>M8</b>	<b>M10</b>	<b>M12</b>	<b>M16</b>
Nominal drill hole diameter	$d_0$ [mm]	10	12	15	18	24
Cutting diameter of drill bit	$d_{cut} \leq$ [mm]	10,45	12,50	15,5	18,5	24,55
Depth of drill hole	$h_1 \geq$ [mm]	75	85	95	115	130
Minimum installation depth	$h_{nom} \geq$ [mm]	60	70	80	100	115
Effective anchorage depth	$h_{ef}$ [mm]	49	59	67	88	99
Diameter of clearance hole in the fixture	$d_f \leq$ [mm]	12	14	17	20	26
Length of the anchor	$L$ [mm]	$t_{fix} + 60$	$t_{fix} + 70$	$t_{fix} + 80$	$t_{fix} + 100$	$t_{fix} + 115$
Torque moment	$T_{inst}$ [Nm]	10	20	45	80	150

**Table 4: Minimum thickness of concrete member spacing, and edge distances**

Anchor size		<b>M6</b>	<b>M8</b>	<b>M10</b>	<b>M12</b>	<b>M16</b>
Minimum thickness of the concrete member	$h_{min}$ [mm]	100	120	140	180	200
Minimum spacing	$s_{min}$ [mm]	50	60	70	80	100
	for $c$ [mm] $\geq$	75	90	100	150	200
Minimum edge distance	$c_{min}$ [mm]	50	60	70	80	100
	for $s \geq$ [mm]	75	90	100	150	200

<b>ATS evo</b>	<b>Annex 4</b> of the European Technical Approval <b>ETA-10/0423</b>
Installation data	

**Table 5: Characteristic values of resistance to tension loads of design method A**

			<b>M6</b>	<b>M8</b>	<b>M10</b>	<b>M12</b>	<b>M16</b>
<b>Steel failure</b>							
Characteristic resistance	$N_{Rk,s}$	[kN]	16	29	46	67	126
Partial safety factor	$\gamma_{Ms}^{1)}$	[-]	1,5				
<b>Pullout failure</b>							
Characteristic resistance in non-cracked concrete C20/25	$N_{Rk,p}$	[kN]	2)	2)	2)	2)	2)
Characteristic resistance cracked concrete C20/25	$N_{Rk,p}$	[kN]	9	12	16	25	2)
Partial safety factor	$\gamma_{Mp}^{1)}$	[-]	1,5 <sup>3)</sup>				
<b>Concrete cone failure and splitting failure</b>							
Effective anchorage depth	$h_{ef}$	[mm]	49	59	67	88	99
Characteristic spacing	$s_{cr,N} = s_{cr,sp}$	[mm]	3 x $h_{ef}$				
Characteristic edge distance	$c_{cr,N} = c_{cr,sp}^{1)}$	[mm]	1,5 x $h_{ef}$				
Partial safety factor	$\gamma_{Mc} = \gamma_{MSp}^{1)}$	[-]	1,5 <sup>3)</sup>				
1) In absence of other national regulation							
2) Pullout failure not decisive							
3) The partial safety factor is including $\gamma_2 = 1,0$							
			<b>M6</b>	<b>M8</b>	<b>M10</b>	<b>M12</b>	<b>M16</b>
Increasing factor for $N_{Rk,p}$ for cracked and non-cracked concrete	$\psi_c$ C30/37	[-]	1,22				
	$\psi_c$ C40/50	[-]	1,41				
	$\psi_c$ C50/60	[-]	1,55				

**Table 6: Displacement under tension load**

	<b>C20/25</b>					<b>C50/60</b>				
	<b>M6</b>	<b>M8</b>	<b>M10</b>	<b>M12</b>	<b>M16</b>	<b>M6</b>	<b>M8</b>	<b>M10</b>	<b>M12</b>	<b>M16</b>
<b>Non-cracked concrete</b>										
Tension load N [kN]	7,7	10,9	13,2	19,8	23,6	7,7	13,9	20,4	30,7	36,6
Short term displacement $\delta_{N0}$ [mm]	0,47	0,81	0,30	0,25	0,20	0,68	1,06	0,60	0,54	0,40
Long term displacement $\delta_{N\infty}$ [mm]	2,38	2,49	1,99	1,12	2,15	2,38	2,49	1,99	1,12	2,15
<b>Cracked concrete</b>										
Tension load N [kN]	4,3	5,7	7,6	11,9	16,9	6,6	8,9	11,8	18,5	26,2
Short term displacement $\delta_{N0}$ [mm]	1,21	0,83	1,25	0,98	0,96	1,40	1,39	0,93	1,36	1,33
Long term displacement $\delta_{N\infty}$ [mm]	2,38	2,49	1,99	1,12	2,15	2,38	2,49	1,99	1,36	2,15

**ATS evo**

Design method A: characteristic values of resistance to tension loads and displacements

**Annex 5**

of the European Technical Approval

**ETA-10/0423**

**Table 7: Characteristic values of resistance to shear loads of design method A**

			<b>M6</b>	<b>M8</b>	<b>M10</b>	<b>M12</b>	<b>M16</b>
<b>Steel failure without lever arm</b>							
Characteristic resistance	$V_{Rk,s}$	[kN]	14	26	42	50	97
Partial safety factor	$\gamma_{Ms}^{1)}$	[-]	1,25				
<b>Steel failure with lever arm</b>							
Characteristic resistance	$M_{Rk,s}^0$	[Nm]	12	30	60	105	266
Partial safety factor	$\gamma_{Ms}^{1)}$	[-]	1,25				
<b>Concrete pry - out failure</b>							
Factor in equation (5.6) of ETAG, Annex C, § 5.2.3.3.	k	[-]	1,0	2,0			
	$\gamma_{Mc}^{1)}$		1,5 <sup>2)</sup>				
<b>Concrete edge failure</b>							
Effective length of anchor in shear loading	$l_f$	[mm]	49	59	67	88	99
Diameter of the anchor	$d_{nom}$	[mm]	10	12	15	18	24
Partial safety factor	$\gamma_{Mc}^{1)}$	[-]	1,5 <sup>2)</sup>				

<sup>1)</sup> In absence of other national regulations.

<sup>2)</sup> The partial safety factor is including  $\gamma_2 = 1,0$ .

**Table 8: Displacement under shear load**

		<b>M6</b>	<b>M8</b>	<b>M10</b>	<b>M12</b>	<b>M16</b>
Shear load	V [kN]	8,0	14,9	24,0	28,6	55,4
Short term displacement	$\delta_{N0}$ [mm]	1,39	1,94	2,71	1,69	2,69
Long term displacement	$\delta_{N\infty}$ [mm]	2,09	2,91	4,07	2,54	4,04

**ATS evo**

Design method A: characteristic values of resistance to shear loads and displacements

**Annex 6**

of the European Technical Approval

**ETA-10/0423**

**Table 9: Characteristic tension resistance in cracked and non-cracked concrete C20/25 to C50/60 under fire exposure - Design Method A**

Fire resistance duration = 30 minutes		M6	M8	M10	M12	M16
<b>Steel failure</b>						
Characteristic tension resistance	$N_{Rk,s,fi,30}$ [kN]	0,2	0,37	0,87	1,69	3,14
<b>Pullout failure</b>						
Characteristic tension resistance	$N_{Rk,p,fi,30}$ [kN]	2,25	3,00	4,00	6,25	8,88
<b>Concrete cone failure</b>						
Characteristic tension resistance	$N_{Rk,c,fi,30}$ [kN]	3,03	4,81	6,61	13,08	17,55

Fire resistance duration = 60 minutes		M6	M8	M10	M12	M16
<b>Steel failure</b>						
Characteristic tension resistance	$N_{Rk,s,fi,60}$ [kN]	0,18	0,33	0,75	1,26	2,36
<b>Pullout failure</b>						
Characteristic tension resistance	$N_{Rk,p,fi,60}$ [kN]	2,25	3,00	4,00	6,25	8,88
<b>Concrete cone failure</b>						
Characteristic tension resistance	$N_{Rk,c,fi,60}$ [kN]	3,03	4,81	6,61	13,08	17,55

Fire resistance duration = 90 minutes		M6	M8	M10	M12	M16
<b>Steel failure</b>						
Characteristic tension resistance	$N_{Rk,s,fi,90}$ [kN]	0,14	0,26	0,58	1,10	2,04
<b>Pullout failure</b>						
Characteristic tension resistance	$N_{Rk,p,fi,90}$ [kN]	2,25	3,00	4,00	6,25	8,88
<b>Concrete cone failure</b>						
Characteristic tension resistance	$N_{Rk,c,fi,90}$ [kN]	3,03	4,81	6,61	13,08	17,55

Fire resistance duration = 120 minutes		M6	M8	M10	M12	M16
<b>Steel failure</b>						
Characteristic tension resistance	$N_{Rk,s,fi,120}$ [kN]	0,10	0,18	0,46	0,84	1,57
<b>Pullout failure</b>						
Characteristic tension resistance	$N_{Rk,p,fi,120}$ [kN]	1,80	2,40	3,20	5,00	7,10
<b>Concrete cone failure</b>						
Characteristic tension resistance	$N_{Rk,c,fi,120}$ [kN]	2,42	3,85	5,29	10,46	14,04

<b>Spacing</b>	$S_{cr,N}$ [mm]	4 $h_{ef}$				
	$S_{min}$ [mm]	50	60	70	80	100
<b>Edge distance</b>	$C_{cr,N}$ [mm]	2 $h_{ef}$				
	$C_{min}$ [mm]	$C_{min} = 2 h_{ef}$ ; if fire attack from more than one side, the edge distance of the anchor has to be $\geq 300\text{mm}$ and $\geq 2 h_{ef}$				

In absence of other national regulation the partial safety factor for resistance under fire exposure  $\gamma_{M,fi} = 1,0$  is recommended.

**ATS evo**

Design method A: characteristic values of resistance of tension load under fire exposure

**Annex 7**

of the European Technical Approval

**ETA-10/0423**

**Table 10: Characteristic shear resistance in cracked and non-cracked concrete C20/25 to C50/60 under fire exposure - Design Method A**

Fire resistance duration = 30 minutes		M6	M8	M10	M12	M16
<b>Steel failure without lever arm</b>						
Characteristic shear resistance	$V_{Rk,s,fi,30}$ [kN]	0,20	0,37	0,87	1,69	3,14
<b>Steel failure with lever arm</b>						
Characteristic bending resistance	$M^0_{Rk,s,fi,30}$ [Nm]	0,15	0,37	1,12	2,62	6,66

Fire resistance duration = 60 minutes		M6	M8	M10	M12	M16
<b>Steel failure without lever arm</b>						
Characteristic shear resistance	$V_{Rk,s,fi,60}$ [kN]	0,18	0,33	0,75	1,26	2,36
<b>Steel failure with lever arm</b>						
Characteristic bending resistance	$M^0_{Rk,s,fi,60}$ [Nm]	0,14	0,34	0,97	1,96	5,00

Fire resistance duration = 90 minutes		M6	M8	M10	M12	M16
<b>Steel failure without lever arm</b>						
Characteristic shear resistance	$V_{Rk,s,fi,90}$ [kN]	0,14	0,26	0,58	1,10	2,04
<b>Steel failure with lever arm</b>						
Characteristic bending resistance	$M^0_{Rk,s,fi,90}$ [Nm]	0,11	0,26	0,75	1,70	4,33

Fire resistance duration = 120 minutes		M6	M8	M10	M12	M16
<b>Steel failure without lever arm</b>						
Characteristic shear resistance	$V_{Rk,s,fi,120}$ [kN]	0,10	0,18	0,46	0,84	1,57
<b>Steel failure with lever arm</b>						
Characteristic bending resistance	$M^0_{Rk,s,fi,120}$ [Nm]	0,08	0,19	0,60	1,31	3,33

<b>Concrete pry out failure</b>		
k factor	k	1,0
		2,0
In Equation (5.6) of ETAG 001 Annex C 5.2.3.3, the above values k factor and the relevant values of $N_{Rk,c,fi}$ from Table 12.6 have to be considered in the design.		

<b>Concrete edge failure</b>
The characteristic resistance $V_{0Rk,c,fi}$ in C20/25 to C50/60 concrete is determined by: $V^0_{Rk,c,fi} = 0,25 \times V^0_{Rk,c}$ ( $\leq R90$ ) and $V^0_{Rk,c,fi} = 0,20 \times V^0_{Rk,c}$ (R120) with $V^0_{Rk,c}$ initial value of the characteristic resistance in cracked concrete C20/25 under normal temperature according to ETAG 001, Annex C, 5.2.3.4.

In absence of other national regulation the partial safety factor for resistance under fire exposure  $\gamma_{M,fi} = 1,0$  is recommended.

**ATS evo**

Design method A: characteristic values of resistance of shear load under fire exposure

**Annex 8**

of the European Technical Approval

**ETA-10/0423**